

WEAKENED PLANE JOINT DETAIL

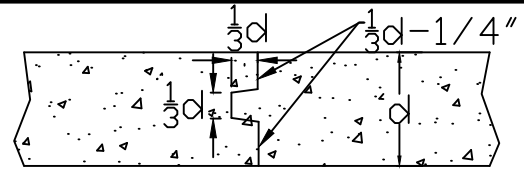

CONSTRUCTION JOINT DETAIL

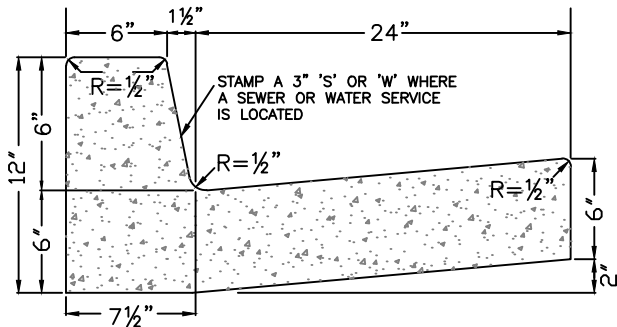

CROSS-SECTION OF MONOLITHIC CURB AND GUTTER

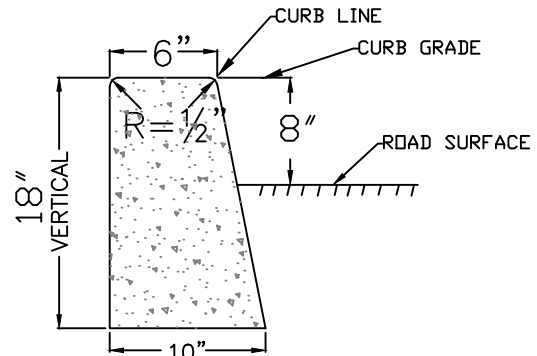

CROSS-SECTION OF CURB

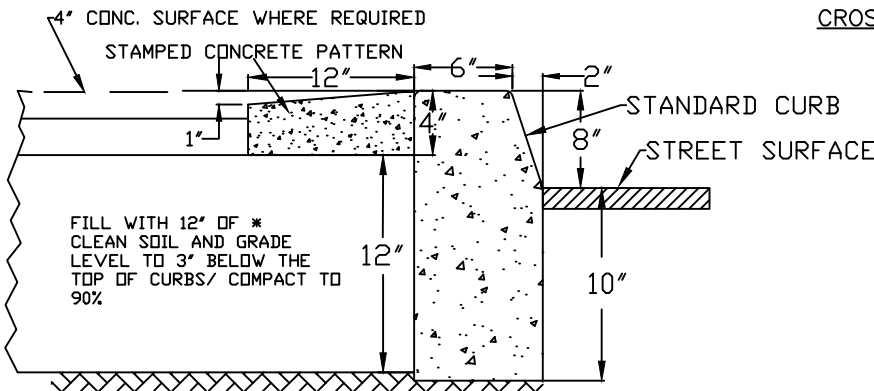

MEDIAN ISLAND CURB DETAIL

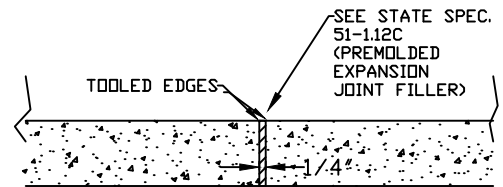

EXPANSION JOINT DETAIL

\*FILL BEFORE PLACING BASE MATERIAL OR COMPACTING IN THE TRAVELED WAY

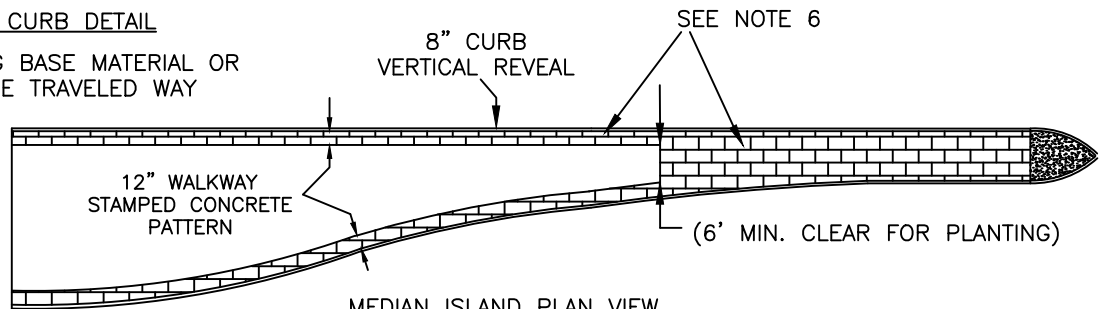

MEDIAN ISLAND PLAN VIEW

Notes:

1. TOP OF CURB TO BE TROWELED AND HAVE A LIGHT BRUSH FINISH. FACE OF CURB TO BE TROWELED AND HAVE A LIGHT BRUSH FINISH. GUTTER TO BE RUBBER FLOATED.
2. 1/4" TO 1/2" FELT EXPANSION JOINT TO BE PLACED AT A MAXIMUM OF 40 FEET AND ADDITIONAL DEEP SCORE JOINTS AT A MAXIMUM OF 20 FEET.
3. ALL WORK TO CONFORM TO SECTION 73 AND 90 CALTRANS STANDARD SPECIFICATIONS.
4. MIN GUTTER FLOW LINE S=0.0015
5. MIN GUTTER DROP AROUND CURB RETURNS IS 0.15 FEET, EXCEPT AT VALLEY GUTTERS.
6. MEDIAN ISLAND PATTERN FOR NOSES AND WALKWAYS: RUNNING-BOND BRICK/COLOR: BRICK RED IMPRINTING TOOLS USED SHALL BE FURNISHED BY THE CONTRACTOR ALL CURBS SHALL CONTAIN 6 SACK PCC CONCRETE.

TYPICAL CURB  
AND  
CURB & GUTTER

REF. & REV.  
MARCH 2005  
FEB. 2011  
OCT. 2014  
NOV. 2017

CITY OF MADERA

ST-12