

**Plan View**

- General Notes:**
1. The enclosure wall shall be six (6) feet high.
  2. Enclosure require at least 50% of space designated for recycling. Allow a minimum of 18" between containers.
  3. 3 or more units on residential require man door.
  4. Grout all cells.
  5. All masonry units shall comply with the latest adopted California Building Code and U.B.C. standard 24-4 Grade N.
  6. All masonry walls shall be inspected by the City.
  7. All masonry units shall be a minimum f'm=1500 psi.
  8. Reinforcing steel shall be deformed bar, minimum Grade 40.
  9. Footing concrete shall be a minimum 2500 psi at 28 days.
  10. Mortar shall be type-S (minimum 1800 psi at 28 days.)  
 One (1) part cement, Type-1.  
 One-half (½) part lime putty or hydrated lime.  
 Four and one-half (4½) parts sand (maximum).
  11. Grout shall be a minimum 2000 psi at 28 days.  
 One (1) part cement.  
 Three (3) parts sand.  
 Two (2) parts pea gravel.
  12. Finish pad elevation to be flush with grade of access pavement.
  13. Gate hinges shall be attached to the steel posts.
  14. Solid gates are required on all enclosures.
  15. 18" for two (2) bins.
  16. Minimum specification for enclosure openings will be 7', not to be encumbered by gates or hinges.
  17. All rebar must be tied at vertical and horizontal intersections.
  18. Maintain minimum 3" clearance from steel to earth for cast-in-place footings.
  19. Drawings not drawn to scale.
  20. A pedestrian access, separate from primary service access is recommended.
  21. Min 20" overlap for rebar. All splices joined with tie wire

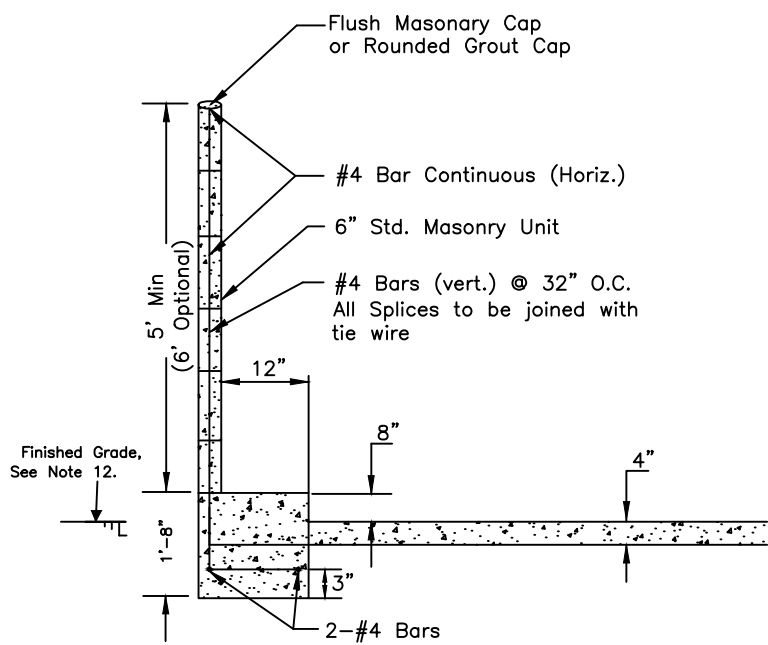

**View "A-A"**

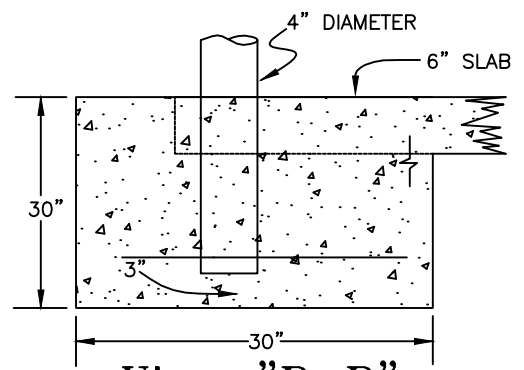

**View "B-B"**

**Typical Section w/ Concrete Block Wall**